

Series 4000

- Fuel Dispensing (Consult Factory) • Water Supply
- Fire Protection • Chemical Transfer

To handle single 3/4" or 1" I.D. hose.

- Lightweight, compact reels designed for long lengths of hose in manual and power rewind.
- Manual rewind reels include: cam-lock drag brake, spring actuated pin lock and removable direct crank rewind.
- Power rewind reels include: chain and sprocket drive powered by electric, hydraulic or air. Strap brake is standard.
- Standard inlet: 90° ball bearing swivel joint, 1" female NPT threads.
- Standard outlet: 1" female NPT threads.
- Standard pressures to 2000 psi (138 bar), available up to 4000 psi (276 bar) – must specify.
- Temperatures from -60°F to +250°F (-51°C to +121°C).
- Rollers and roller mounting brackets are accessory items. Specify roller position.



Electric rewind
Standard
configuration
shown



Optional External Mounting Brackets

Part No. 9906.0027.

Add 2 1/2" to the X dimensions shown in the chart.

PARTS DRAWING – ISO 68

Model Number <small>For power rewind see Note 5</small>	Hose Capacity of Reel feet / m			Approx. Weight Crank Rewind lb. / kg <small>See Note 3</small>			Reel Dimensions*** in. / mm						
	I.D. in. mm	3/4	1	NET	UPS/ FedEx SHIP Wt.	Freight SHIP Wt.	A	B	E CRANK	E POWER	F CRANK	F POWER	X
	O.D. in. mm	1-9/32	1-1/2										
4018-17-18	50	35	36	80*	71	15	10	16.5	19	27.75	20.5	13.5	
	15	11	16	36	32	381	254	419	483	705	521	343	
4024-17-18	100	50	48	98*	81	21	16	16.5	19	33.75	26.5	19.5	
	30	15	21	45	37	533	406	419	483	857	673	495	
4030-17-18	150	75	57	110*	92	27	22	16.5	19	39.75	32.5	25.5	
	46	23	26	50	42	688	559	419	483	1010	826	648	
4038-17-18	200	100	70	-	124	35	30	16.5	19	47.75	40.5	33.5	
	61	30	32	-	56	889	762	419	483	1213	1029	851	

Notes:

- Specifications subject to change.
- Upon request, reels can be supplied with drum lengths other than shown.
- Weights shown in chart are for crank rewind models. ADD these amounts for power rewind models (does not apply to FedEx or UPS):

	Net lbs./kg	Ship lbs./kg
Electric	18/8.2	18/8.2
Hydraulic	15/6.8	15/6.8
Air	15/6.8	15/6.8
- Dimension "F" is the overall length of standard model reels. Crank rewind reels require 3-1/2" clearance to remove or install crank handle.
- When ordering power rewind models, prefix model number with:
 - A = Air Rewind – Supplied with control valve and 18" air hose.

- E = Electric Rewind – 12v and 24v DC rewind reels are supplied with switch and solenoid; 115v AC rewind reels are not supplied with switch but can be ordered separately.
 - HD = Hydraulic Rewind – Not supplied with control valve.
 - 6. **Finish:** Refer to page 3.
 - 7. **Be sure to check dimensions and weights prior to ordering.**
 - 8. Some roller options may prohibit the use of our molded chain guard.
- NOTICE:** A flexible connector must be used between the inlet pipe and the inlet swivel joint.
* Dimensional weight applies when shipped as a parcel package (via FedEx or UPS Ground).
*** X, Y indicate mounting holes. See page 5. (Also applies for external mounting brackets.)

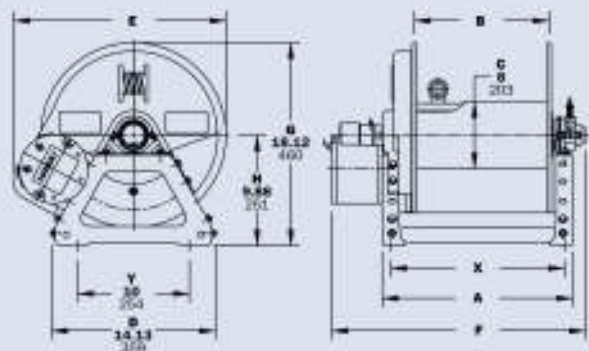

Power rewind shown